

Understand the memory interface of the 8086 microprocessor

Prepared by
Afifa Hoque

Memory Interface

- ▶ An external memory interface is a **bus protocol for communication from an integrated circuit, such as a microprocessor, to an external memory device located on a circuit board.**

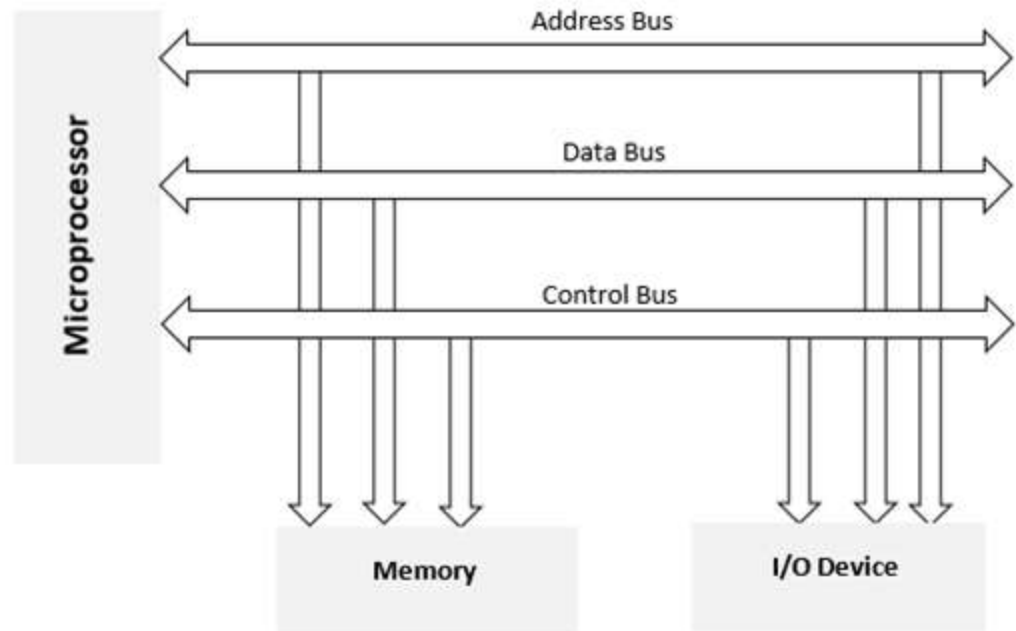

Sketch the 8086 microprocessor system memory interface

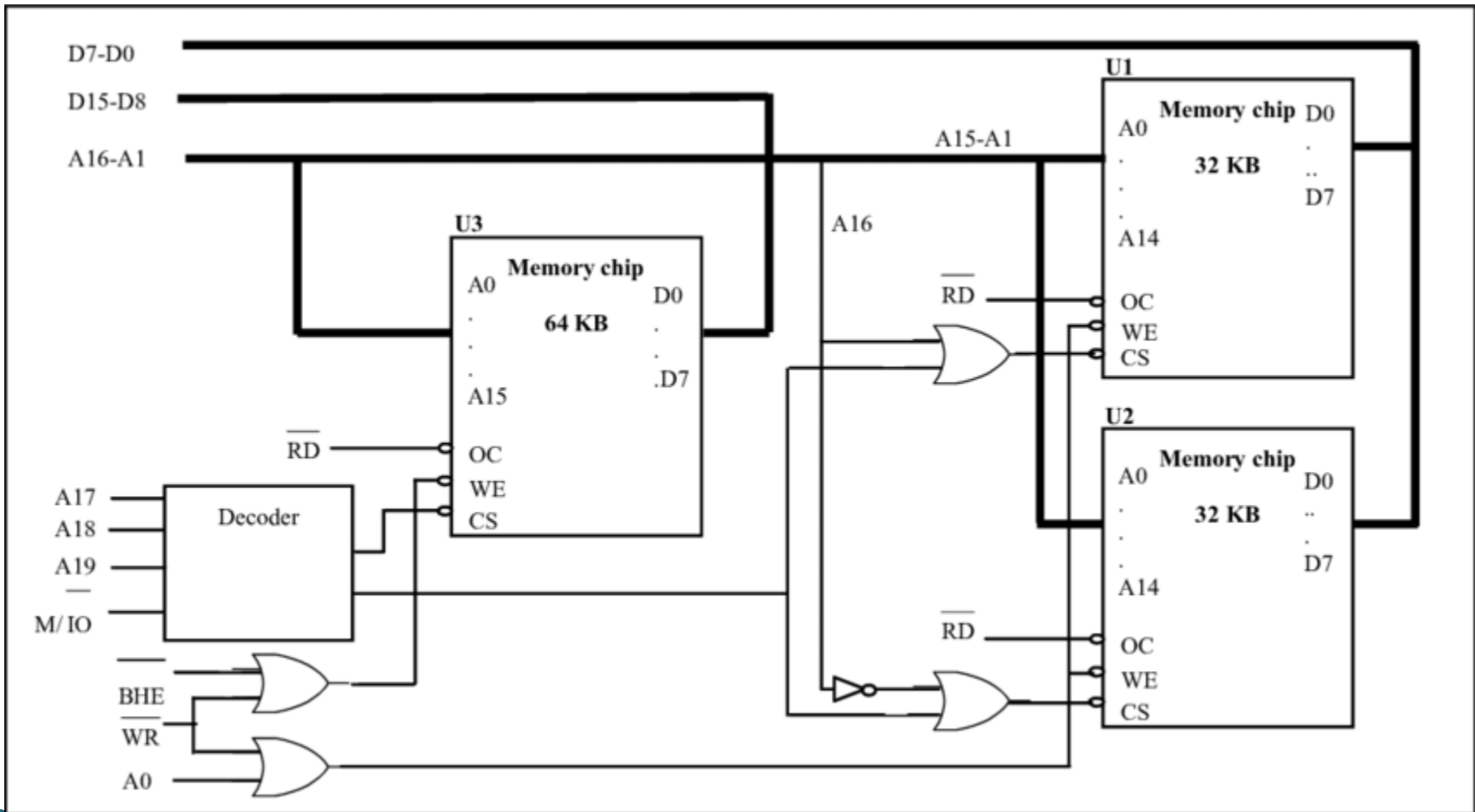

State the meaning of even and odd address

Even and odd memory banks of 8086

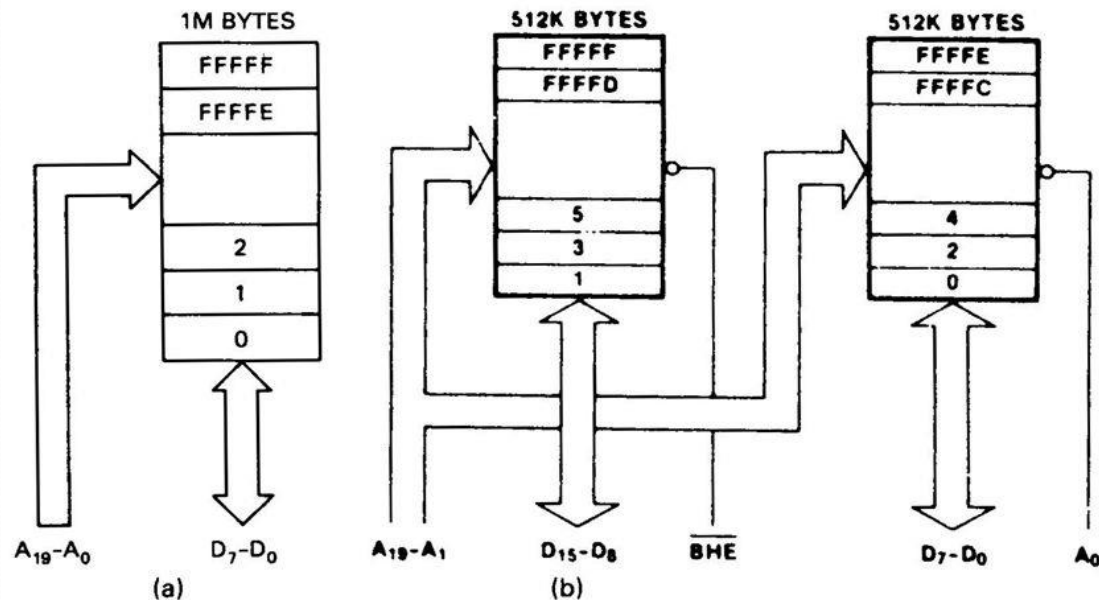

1 M-Byte Address space of 8086

